



AE-12

Subwoofer Cabinet Manual

Thank you for purchasing AUDIO SYSTEM car horns. It is a state-of-the-art product specifically designed and engineered for vehicle use, and has been thoroughly tested to ensure consistent and reliable performance.

Should you have any questions regarding the installation or operation of your AUDIO SYSTEM Subwoofer Speaker, which are not answered in this manual, please contact your dealer for assistance.

FEATURES

12" Subwoofer Speaker
 Rms.Power: 150W
 Rubber Edge Paper Cone
 Dual 4 ohm 2" Aluminum Voice Coil
 65 Oz Magnet Structure
 Dedicated with LOGO basin frame
 PVC Gasket

DIMENSIONS

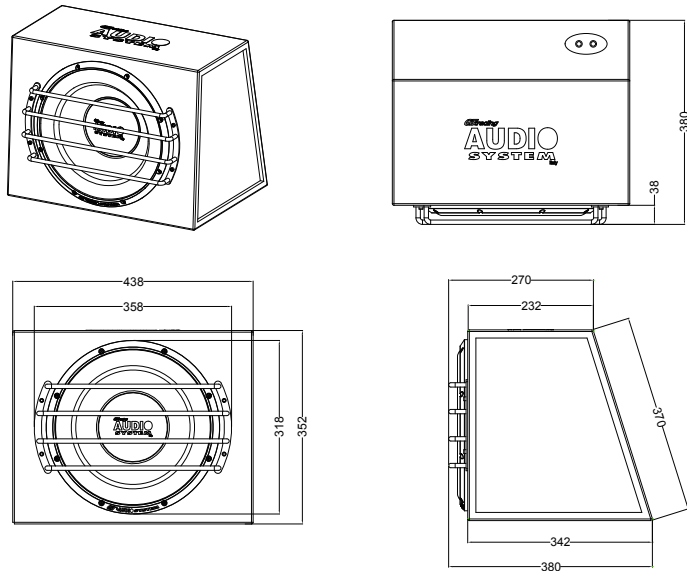

PRECAUTIONS

- Before installation, make sure that the installation space is appropriate
- To prevent noise pick-up, keep the wiring away from motors, highvoltage leads and other potential noise sources.
- To prevent a short-circuit, keep all wiring away from moving parts and sharp edges.
- Make sure you carefully read and understand the installation instructions before installing this subwoofer in your vehicle.

| SPECIFICATIONS | AE-12 |
|--|------------------------|
| Rms.Power (W) | 150 |
| Minimum resonant speaker frequency(Hz) | 26 |
| Minimum resonant box frequency(Hz) | 45 |
| Nominal Impedance (Ω) | 4 |
| Sensitivity@1w/1m (dB) | 86.5 |
| Frequency Range | 26Hz~1KHz |
| Magnet | 63 Oz |
| Voice Coil | 2" |
| Cone | Rubber Edge Paper Cone |
| Mounting Depth (mm) | 146 |
| Mounting Diameter (mm) | 283 |
| Box size (HxWxD1xD2mm) | 438x352x270x380 |