

ER + M SERIES
BY AUDIO SYSTEM

since 1988

AUDIO SYSTEM

the sound

HIGH-PERFORMANCE CAR- AMPLIFIER

OWNER'S MANUAL



CE

R-1250.1 D

R-1250.1 D-24V

M-850.1 D

Congratulation on your purchase of your new **R + M SERIES** amplifier.

IMPORTANT: Before installation your power amplifier, we recommend to read the owner's manual carefully and to follow the instructions regarding connection and fitting exactly.

ATTENTION: Pay attention to advices and instructions of the car manufacturer.

IMPORTANT: Your proof of purchase is evidence of warranty claim for repair or replacement. Keep your proof of purchase, manual and original packaging.

ATTENTION: Use of sound components can impair your ability to hear necessary traffic sounds and may constitute a hazard while driving your automobile.

AUDIO SYSTEMGERMANY accepts no liability for hearing loss, bodily injury or property damage as a result of use or misuse of our products.

We recommend installing the equipment by an authorized service center or dealer. A professional fitting and connection is the requirement for further warranty and perfect sound.

R-1250.1 D / M-850.1 D

- * 1-Channel digital Mono-High-Power amplifier
- * High efficiency of max. 84 %
- * Stable into 1 Ohm mono
- * Variable Low Pass Filter from 30 to 150 Hz
- * Variable Subsonicfilter from 10 to 50 Hz
- * Variable Phase Shift from 0° to 180°
- * Variable Bass-Boost from 0 - 6 dB to 45 Hz
- * Input Sensitivity from 0,3 to 8 V
- * **Multi-Way Protection Circuitry:** overheating, overcurrent, short circuitry and speaker DC protection
- * Operation Voltage from 10 to 16 V
- * Wired Remote Controller **RTC**
- * High-Level-Input with automatically „TURN ON“
- * Adapter cable **HLAC** und **RCA HI**(optional)



R-1250.1 D-24V

- * see above, except: Operation Voltage from 20 to 28 V



R-1250.1 D / M-850.1 D / R-1250.1 D-24V

1. Battery disconnection:

First, disconnect the power supply of the vehicle by removing the ground cable of the battery.

2. Ground connection:

Connect the GND (ground) connection of the amplifier with the car chassis. Keep this cable as short as possible (not longer than 50 cm) and use a suitable cross section (AWG size 7-5). Make sure, that the connection with the vehicle chassis is free of paint, dirt and dust.

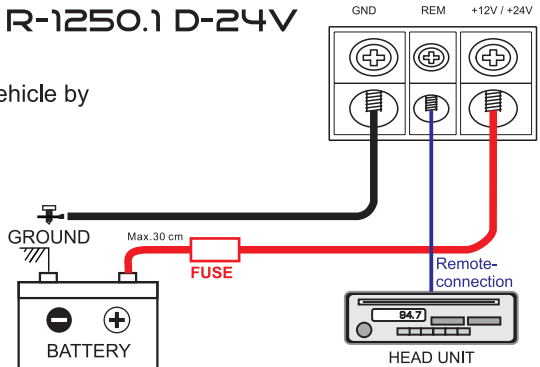

3. +12 V Power connection: Connect the +12 V / +24 V contact of the amplifier with the supply cable via a fuse directly to the vehicle battery. Keep in mind, that the length of the cable from fuseholder to vehicle battery has to be maximum 30cm. For the amplifier to function at its best, use a high quality fuse holder and suitable cable preferably AWG 7-5 cable. This fuse protects the amplifier and the vehicle against the possibility of a short circuit in the power cable.

4. Remote connection: Connect the REM-terminal of the amplifier to the remote-output (automatic 12 V / 24 V antenna-output) of the head unit. Use a 0,5 - 1,5 mm² power cable. The R 1250 D.1 has a remote out (RO) for additional amplifier.

5. HI/LOW selectable button: If the radio (normally original radio) has no RCA output and remote output (automatic 12 V / 24 V antenna output) it is possible to connect the speaker output from headunit direct in RCA input. The HI/LOW button must be switched to „HI“. If the SERIES amplifier gets a signal from head unit output, the amplifier will turn on. Accessoires: RCA-HI and HLAC adapter cable.

⚠ Caution ⚠

Please take the following precautions when installing your amplifier:

- a) Take extra care when making the connections. Make sure that no electrical cable, gas tank, hydraulic brakes or other components get damaged.
- b) Allow enough cooling and air circulation and avoid installing the unit in small closed boxes or close to parts that heat up easily.
- c) Keep the amplifier away from liquid, moisture, heat and foreign materials.
- d) This amplifier can only be used in vehicles with 12V / 24V DC power supply.
- e) Never install the power supply cable with other original vehicle wires (gas cables), fan motors, control modules etc.
- f) Install the signal cable (cinch cable) as well as speaker cable far away from the power cables to avoid interference with music signals.
- g) To avoid dangers of cables binding, squeezing or breaking, use the cables supplied with your amplifier.

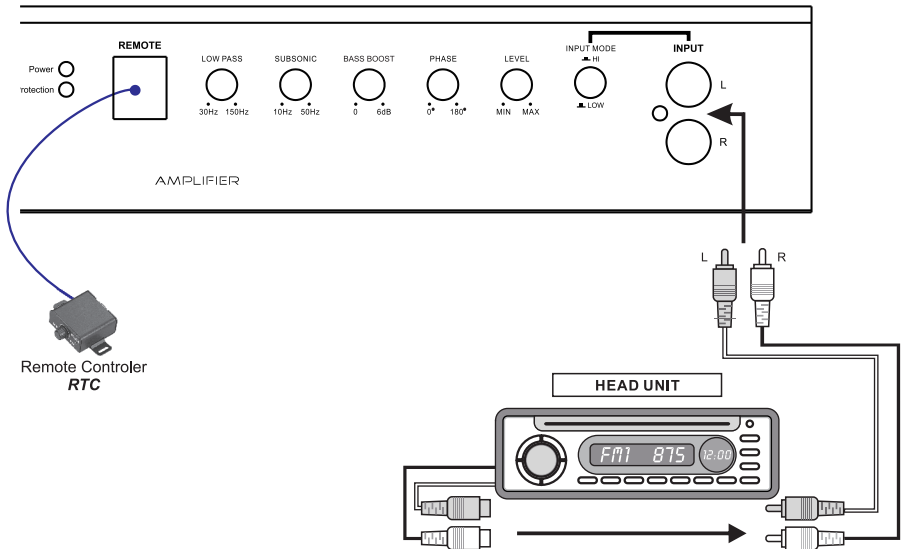

The **SERIES** amplifier offers RCA-Inputs, which are connected through cinch cables with the preamplifier-outputs of the head unit. **HLAC** and **RCA HI** adapter cable can be purchased as accessories if the head unit has no RCA output.

The HI/LOW button must be switched to „HI“. If the **SERIES** amplifier gets a signal from head unit output, the amplifier will turn on.

Important in this respect is, that first the **gain-control** of the connected amplifier is put to **minimum**. Turn up only if necessary.

With the aid of the variable subsonicfilter, lowpassfilter, phase shift-controller, bass boost and the gain-controller you are able to adjust the amplifier on to your preferred taste of hearing, the circumstances of the vehicle and to the speakers.

Optional a wire remote controller RTC (enclosed) can be installed. It allows you to rule the amplifier in front of the car.

In this regard, **AUDIO SYSTEM GERMANY** recommends to adjust your amplifier through a specialized service center, dealer or a specialist.

R-1250.1 D / R-1250.1 D-24V

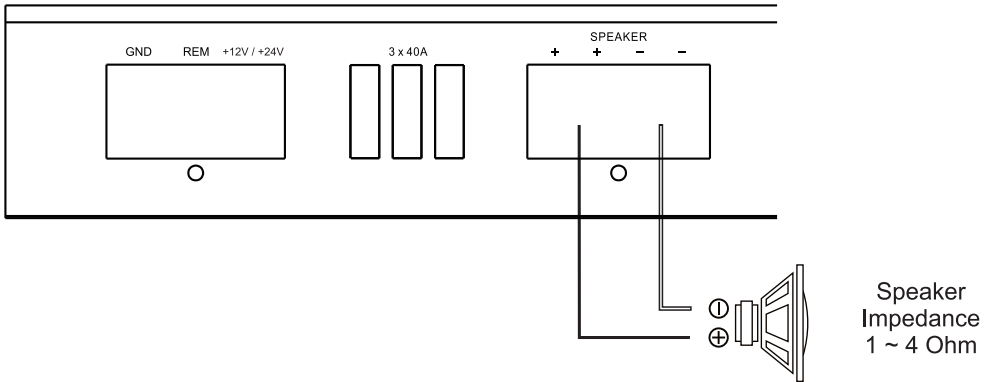

Please note that this unit is a mono block amplifier and has only one channel. Connecting to either the positive or negative of either of the two connections will end in the same result as both positive connections (or both negative connections) are tied together inside the unit. For example, if you connect two 2 ohm subwoofers, the amp will parallel the connections for a 1 ohm load.

M-850.1 D

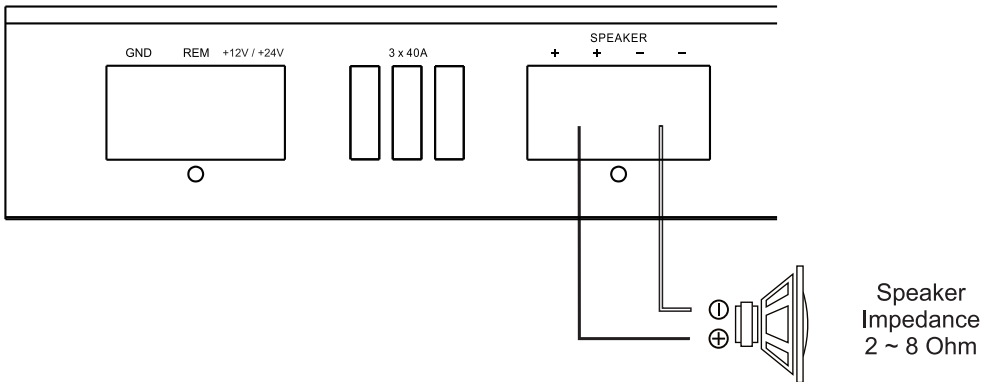

Please note that this unit is a mono block amplifier and has only one channel. Connecting to either the positive or negative of either of the two connections will end in the same result as both positive connections (or both negative connections) are tied together inside the unit. For example, if you connect two 4 ohm subwoofers, the amp will parallel the connections for a 2 ohm load.

This power amplifier is featured with an efficient protection system to prevent any damages like over-heating, overvoltage, short-circuit and DC at the loudspeaker output. Occuring an error the protection-LED will light in red.

In order to check the problem, first turn down all levels of the head unit, afterwards turn it off.

<p>AMPLIFIER IS NOT POWERED UP, NO LED IS LIGHTENING</p>	<ul style="list-style-type: none"> - ground connection professional connected? - +12V powercable professional connected? - remote cable professional connected? - fuses inserted and alright? - analyze voltage on the amplifier.
<p>PROTECTION LED ILLUMINATES GREEN WHILE AMPLIFIER IS SOUNDLESS</p>	<ul style="list-style-type: none"> - cinch cable alright and professional connected? - loudspeaker professional connected? - head unit alright?
<p>PROTECTION LED ILLUMINATES RED WHEN AMPLIFIER IS POWERED UP</p>	<ul style="list-style-type: none"> - amplifier too hot? - short-circuit at the loudspeaker output? - short-circuit caused by loudspeaker cable with vehicle chassis (ground)? - input voltage too high (e.g.faulty generator)?
<p>OVERHEATING (PROTECTION LED ILLUMINATES RED WHEN AMPLIFIER IS POWERED UP)</p>	<ul style="list-style-type: none"> - impedance alright? - loudspeaker error? - adequate airflow of the amplifier? <p style="text-align: center;">! CAUTION !</p> <p>After cooling down, the amplifier turns on</p>
<p>ERROR IN AMPLIFIER FUSE</p>	<ul style="list-style-type: none"> - ground professional connected? - loudspeaker impedance alright? <p style="text-align: center;">! CAUTION !</p> <p>Make sure when changing fuses to use the same value.</p>
<p>SOUND TOO LOW OR LOW-DISTORTED SOUND</p>	<ul style="list-style-type: none"> - input level control "GAIN" is set to match the head unit? - output level control of the head unit alright? - loudspeaker error? - loudspeaker cable checked? - crossover frequencies has been properly set? (Check head unit, ampliflier, DSP, soundprozessor, equalizer,
<p>HIGH HISS-ENGINE NOISE IN SPEAKERS</p>	<ul style="list-style-type: none"> - ground connection professional connected? - short-circuit caused by loudspeaker cable with vehicle chassi (ground)? - cinchcable (RCA) and/or loudspeaker cabel installed too close to the power connection cable? - cinch ground (RCA) of the head unit alright?

⚠ ATTENTION ⚠

Please contact your specialized dealer if the amplifier is still not working after it has been checked with the error list!

For warranty adjustement / repairs the original invoice has to be attached!

Opening the power amplifier is leading to a lost of warranty in either case!

R-1250.1 D

Power Supply Voltage	10 - 16 V
Rated Power Output at 14,4 V / 3% THD	
-RMS power @ 4 ohm mono	1x 500 W
-RMS power @ 2 ohm mono	1x 900 W
-RMS power @ 1 ohm mono	1x 1250 W
Signal to Noise Ratio	>96 dB
Low Pass Crossover	30 ~ 150 Hz
Subsonic filter	10 ~ 50 Hz
Frequency Response	10 Hz ~ 150 Hz (+/-3 dB)
THD@RMS Watts	< 0,061%
Fuse Rating	3x 40 A
Input Sensitivity	300 mV ~ 8 V (+/- 5%)
Dimensions	380(L) x 50(H) x 185(W) mm



M-850.1 D

Power Supply Voltage	10 - 16 V
Rated Power Output at 14,4 V / 3% THD	
-RMS power @ 4 ohm mono	1x 275 W
-RMS power @ 2 ohm mono	1x 500 W
-RMS power @ 1 ohm mono	1x 850 W
Signal to Noise Ratio	>96 dB
Low Pass Crossover	30 ~ 150 Hz
Subsonic filter	10 ~ 50 Hz
Frequency Response	10 Hz ~ 150 Hz (+/-3 dB)
THD@RMS Watts	< 0,061%
Fuse Rating	2x 40 A
Input Sensitivity	300 mV ~ 8 V (+/- 5%)
Dimensions	292(L) x 50(H) x 185(W) mm

R-1250.1 D-24V

Power Supply Voltage	20 - 18 V
Rated Power Output at 24 V / 3% THD	
-RMS power @ 4 ohm mono	1x 500 W
-RMS power @ 2 ohm mono	1x 900 W
-RMS power @ 1 ohm mono	1x 1250 W
Signal to Noise Ratio	>96 dB
Low Pass Crossover	30 ~ 150 Hz
Subsonic filter	10 ~ 50 Hz
Frequency Response	10 Hz ~ 150 Hz (+/-3 dB)
THD@RMS Watts	< 0,061%
Fuse Rating	3x 40 A
Input Sensitivity	300 mV ~ 8 V (+/- 5%)
Dimensions	380(L) x 50(H) x 185(W) mm

